

# SCHIZOCHROAL EYES AND VISION OF SOME SILURIAN ACASTID TRILOBITES

by E. N. K. CLARKSON

**ABSTRACT.** The eyes of some British Silurian Acastinae are described and analysed functionally. Techniques are given for measuring the size and spatial arrangement of the lenses of schizochroal eyes and the angular bearings of their lens-axes, from which may be inferred the angular range of vision of the whole eye and the relative visual acuity in different directions. In the post-larval ontogeny of the eye of *Acaste downingiae* (Salter) the lens-number increases with size but the angular extent of the visual field remains constant. Two eye-variants are distinguished and attributed tentatively to sexual dimorphism. Comparisons are made with the adult eyes of *Acaste downingiae macrops* (Salter) and *Acastoides constricta* (Salter).

Variation of lens-size and strong differentiation between the relative acuity in the horizontal and vertical directions of vision are perhaps the most significant features of the eyes of Acastinae, and the latter is interpreted as indicative of movement-perceiving eyes. Analogies are made with the compound eyes of recent arthropods, and the ecological significance of the work is briefly discussed.

TRILOBITES are amongst the earliest arthropods to appear in the geological record and are the oldest fossil animals known to have possessed compound eyes. The morphological similarity between the eyes of trilobites and those of other arthropods was noted by the first students of trilobite morphology, including Quenstedt (1837) and Burmeister (1846). Since then, trilobite eyes have been studied in detail by many workers; in particular Barrande (1852), Clarke (1889), Lindstrom (1901), Brink (1951), and Beckmann (1951). An excellent summary of current knowledge is given by Harrington (1959) in the *Treatise on Invertebrate Paleontology* Part O (Arthropoda I), pp. O 87–O 92. In the main these workers have contributed to our knowledge of the morphology and development of trilobite eyes, and there has been little attempt to relate structure to function.

I have made a functional study of the eyes of a number of species of trilobites. This paper presents the results of the first part of this investigation and concerns a small group of trilobites which have proved especially suitable for such functional analysis.

Within the Trilobita there are two distinct types of eyes, defined by Clarke (1889) as 'holochroal' and 'schizochroal'. Full descriptions of the two types are given by Harrington, and it is sufficient to state here that holochroal eyes consist of many small closely packed lenses overlaid by a single corneal membrane, through which the lenses may usually be seen. Schizochroal eyes have a fairly small number of relatively larger lenses, the maximum number recorded being 770 (Roy 1933). Each lens has its own cornea, and is separated by interstitial material from its neighbours. Whereas holochroal eyes are present in trilobites of all ages from Lower Cambrian to Middle Permian, schizochroal eyes, which are to be found only in the Phacopina, a few Cheirurina and, possibly, Harpina, do not occur before the Ordovician or after the Devonian. They are consequently to be regarded either as a specialized development of the normal holochroal pattern or as quite distinct organs of independent origin. As yet it is not known which of the two possibilities is the more probable. The suborder Phacopina, in which only schizochroal eyes occur, appeared in the early Ordovician after the main

lines of trilobite descent had been established (Stubblefield 1959), and reached its acme comparatively late in the history of the Trilobita when the class as a whole was declining.

Schizochroal eyes of Phacopina have been found to be particularly suitable for use in the investigation of the nature of trilobite vision because of their large size and few lenses. Several species of Phacopina are common in the English Wenlock Limestone (Silurian); amongst them are Acastinae in a state of preservation suitable for study. These are described in this paper.

#### TERMINOLOGY

The eyes of Phacopina have been frequently figured and Lindstrom's (1901) magnificent monograph contains figures of some of these eyes in thin section. Their detailed morphology has seldom been described. In the succeeding text descriptions, although the terminology of the *Treatise* following Warburg (1925) has been used, it has been necessary to supplement this with a number of new terms.

These terms, illustrated in text-fig. 1, are applicable to the eyes of *Acaste* and all other Phacopina. The external surface of the eye which bears the lenses and is bounded by the facial suture is known as the '*visual surface*'. The limits of the visual surface nearest to the sagittal line are defined as the '*anterior*' and '*posterior edges*'. The '*interlensar sclera*', defined by Clarke (1889), is that part of the visual surface which lies between the schizochroal lenses and is not covered by cornea. It is generally identical in structure with the rest of the cephalic exoskeleton.

All the lenses are invariably arranged conspicuously in hexagonal close packing and thus form three intersecting rows, defined as the '*dorso-ventral files*' and the '*ascending*' and '*descending diagonal rows*'. The former term is intended to replace the somewhat misleading expression 'vertical rows', as these files usually diverge ventrally and are not always vertical. Since the dorso-ventral files are more frequently referred to in the text than the other rows, the term '*file*' by itself is normally used to distinguish them. The files are numbered 1, 2, 3, . . . etc., from the anterior edge of the eye. Lenses occur in alternate files at the same level from the front to the rear of the visual surface, and lie in '*horizontal rows*'. The '*upper horizontal row*' is defined as that which extends the full distance below the facial suture. Within this row the central lenses are always smaller than the outer ones. In *Acaste* and other Phacopina there is often an '*accessory upper horizontal row*' lying above the latter. It is confined to the posterior part of the visual surface and generally consists of a few lenses only. In some cases the regularity of the pattern in which the lenses are distributed is disrupted by the interpolation of one or two extra lenses between certain files. The files on either side of these extra lenses are usually bowed outwards, but a short distance from the hiatus all the files are quite straight and normal in appearance. This condition has been observed in a small specimen of *Acaste downingiae* s. str. (Salter), SM A 28744 (text-fig. 4a, b, Pl. 1, figs. 1, 4, 5).

Discussion of the angular relationships of the lens-axes involves the use of the terms '*longitudinal*' and '*latitudinal axial angles*' which refer to the measurable angles of separation between the axes of adjacent lenses. Since the lenses in two neighbouring files are situated at different levels and hence usually have incongruent latitudinal bearings, the longitudinal axial angles are taken as half the angle between the axis of any one

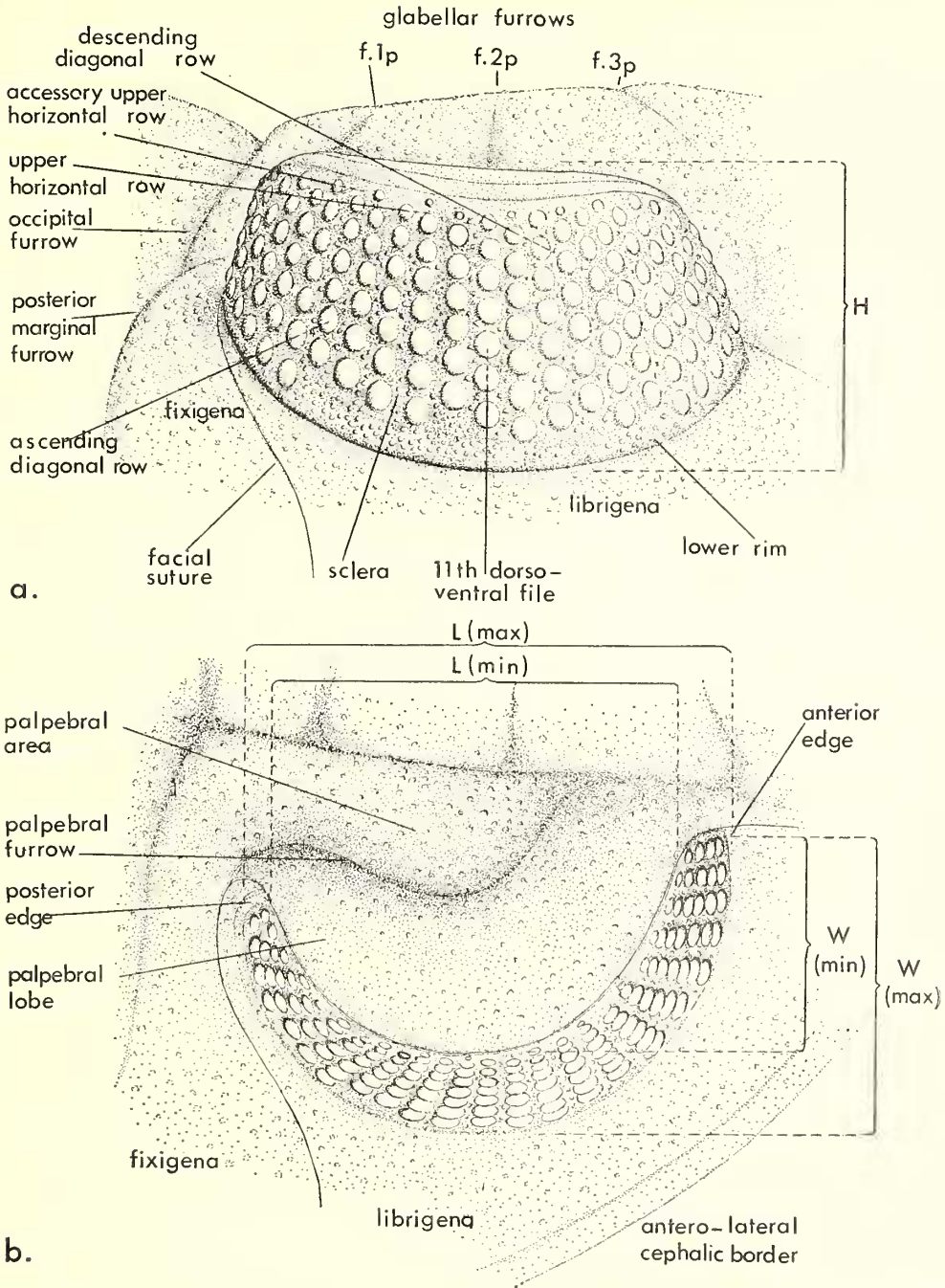

TEXT-FIG. 1. *Acaste downingiae* (Salter) s. str. External morphology of eye and immediate environs, After SM A 28720 (eye-variant A); *a.* Lateral view. *b.* Dorsal view. Dimensions; L, W, H, length, width, height.

lens and that of the lens in the same horizontal row (i.e. at the same level) in the next file but one. A latitudinal axial angle is the angle of separation between the axis of any lens and that of the lens directly above or below it in the same dorso-ventral file.

The term '*facet*' which has sometimes been substituted for '*lens*' is not used here since it has already been applied in trilobite terminology to designate the articulating antero-lateral part of the thoracic pleurae in trilobites capable of enrolment.

#### TECHNIQUE OF INVESTIGATION

A simple apparatus was devised in order to measure accurately the angular bearings of the individual lenses of schizochroal eyes. A set of such measurements of all the lenses of one eye, when plotted graphically, gives the total angular range of vision, and the angular separations between the lens-axes. This apparatus was also used for a detailed study of the sizes and the spatial arrangement of these lenses, and their mode of development during postlarval ontogeny.

*Apparatus.* The apparatus (text-fig. 2) consists of two units: a stereoscopic microscope fitted to a long arm stand, allowing the optical assembly to be either horizontal or vertical, and a turntable. (The microscope illustrated is by W. R. Prior & Co. Ltd.) The specimen selected for analysis is fixed firmly on the horizontal turntable, which can be rotated so that different parts of the visual surface of the eye may be examined in turn.

The optical system used has a maximum magnification of  $\times 40$ . The left eyepiece (A) may be fitted either with a micrometer scale registering to  $\frac{1}{10}$  mm. for measurement of lens diameters and spacing, or with interchangeable graticules ruled in 0.5 mm. or 0.25 mm. squares. An aluminium collar (B) with its pointer (C) was fitted to the left eyepiece. This can be locked by the screw (D). In determining the angular bearings of the lens-axes the pointer (C) is aligned parallel with one of the sets of lines on the graticule. The whole eyepiece assembly complete with collar and pointer may be rotated inside its barrel. An immovable protractor (F) is held by a Perspex collar (G) on the barrel of the eye-piece below the aluminium collar. The 90° bearing of the protractor is fixed horizontally, and upon rotation of the eyepiece assembly any angle measured by means of the graticule will be shown by the pointer (C) on the protractor. To avoid rotation of the graticule during measurement the eyepieces have been adjusted for personal eye-spacing. They are locked by means of the clamp (E).

The rigid turntable consists of an immovable 6½ in. wooden disc (H) on which is fixed a 6-in. circular protractor (J). Above the protractor is a rotating upper assembly of Perspex. This consists of three graduated discs, of which the lowermost (K) is the largest, and has a pointer (L) bearing on the protractor (J). This disc rotates about a central screw, and has on its upper surface two parallel bars grooved so that the dovetailed fixture (N) of the base of the next disc (M) may slide between them. This disc (M) carries on its upper surface another dovetailed fixture at right angles to that on the lower surface, engaging with grooved bars on the lower surface of the uppermost disc (P). The plane surface of the top disc (P) is inscribed with two sets of lines at right angles, one parallel to the pointer (L), the other perpendicular to it. If the specimen is mounted in plasticine on the upper disc, either of its eyes may be brought into the field of view of the microscope by sliding the discs, and held level whilst the stage is rotated.

*Orientation of the trilobite.* All measurements of the angular bearing of the lens-axes are made with primary reference to the trilobite's plane of bilateral symmetry, the sagittal line. This line is orientated parallel with one of the lines engraved upon the upper surface of the disc (P), so that its bearing can be measured on the protractor (J) by means of the pointer (L).

The chief problem arises in the orientation of the cephalon in profile, i.e. with respect to the horizontal plane of the apparatus. A conventional 'horizontal' orientation has been chosen which probably approximates to the original attitude of the cephalon as it was in life (p. 27). This orientation is defined as that in which the upper edge of the visual field, or at least the greater part of it, lies along a single latitude. In this attitude the 'horizontal' rows of lenses in the eye are in fact aligned horizontally, a feature which may be used in practice as a guide to the orientation of the specimen on the stage.

*Size and spacing of lenses.* It is desirable to make a graphical representation of the whole visual surface, in order to show the number, size, and spacing of the lenses in every file, and to trace their ontogenetic

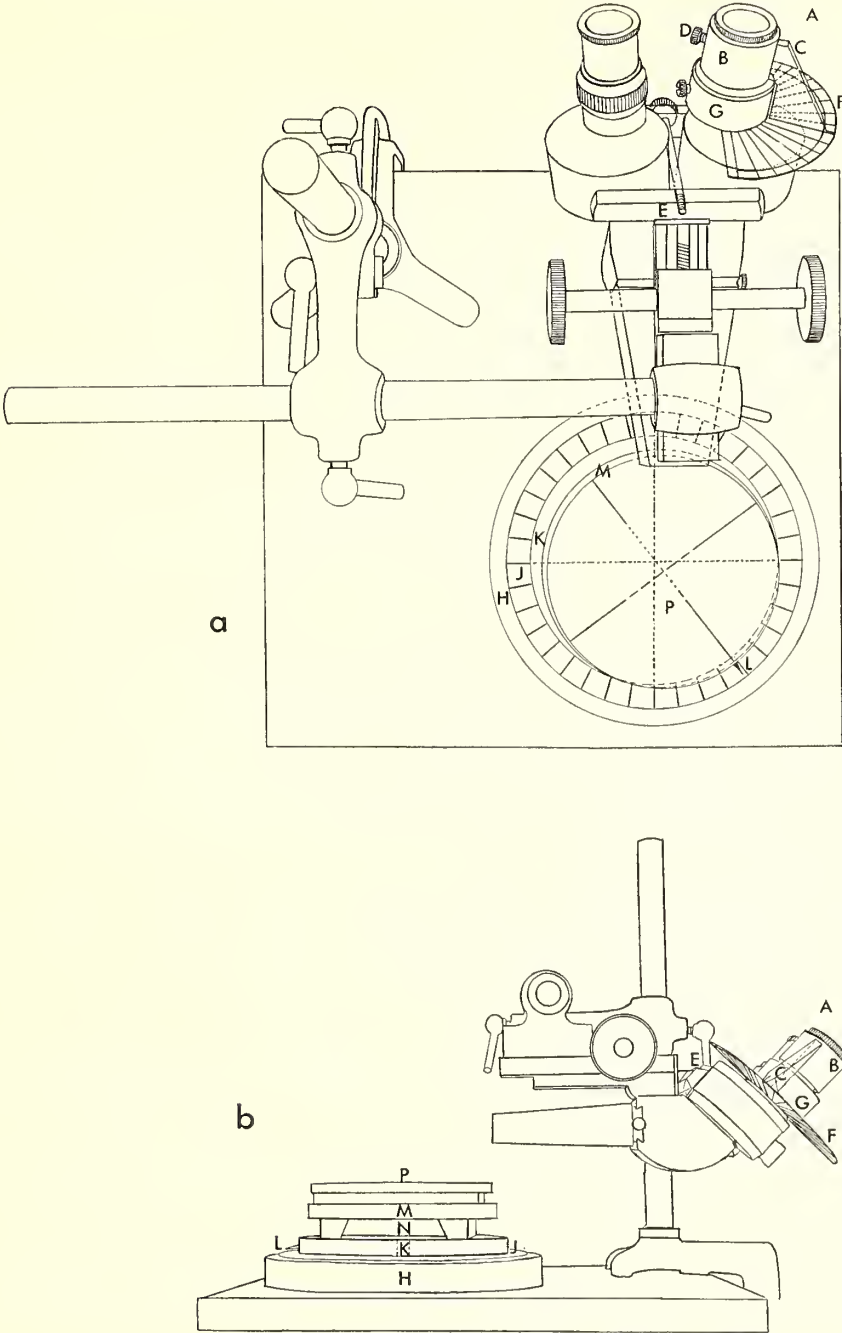

TEXT-FIG. 2. Apparatus used in the investigation of vision in trilobites. *a*, *b*, perspective views from top and side. Explanation in the text.

development and intraspecific variation. Although Barrande (1852, p. 514) had drawn up a table showing intraspecific variation in the number of lenses per file in *Phacops secundus* Barrande, Clarke (1889), working with *Phacops rana* (Green), was the first to attempt to show diagrammatically the number and arrangement of the lenses. He represented each lens as a dot equidistant from its neighbours. The dorso-ventral files were shown as vertical, and the diagonal rows as inclined at  $60^\circ$  to the vertical. Beckmann (1951) used a similar method, but showed the diameters of the lenses with greater accuracy. Although this projection can give an accurate representation of the sizes of the lenses it necessarily distorts their relative positions.

The problem, as in cartography, is to find an appropriate projection which will depict a portion of an approximately spherical surface with minimal distortion. The projection chosen resembles a conical equidistant projection in character though not in method of construction. This projection (text-fig. 4) shows both the spacing of the lenses and their diameters with relatively little distortion. The method of construction used is as follows (text-fig. 3). A long central file (A) is selected and observed in profile; the distances between the lens centres may then be measured accurately by the eyepiece micrometer and plotted on paper at an appropriate magnification (text-fig. 3c). The specimen is then turned so that the visual surface is perpendicular to the observer, and the distances between the lens-centres of adjacent files are measured by triangulation from the lenses of the marked file A whose positions have already been recorded.

The lenses of files B and C are normally at equal distances from those of file A and one set of measurements will therefore suffice for both. The positions of the lens-centres of further files are then plotted in the same way giving a grid for all the lens-centres. Slight irregularities in spacing often occur near the anterior and posterior edges of the visual surface and in such cases separate measurements must be made for the spacing of each lens. When the grid is complete the measured diameters of all the lenses may be drawn in.

*Angular bearings of the lens-axes.* Before measuring the angular bearings of the lens-axes, the eyes are lightly coated with ammonium chloride and are illuminated against a dark background. The longitudinal and latitudinal components of the angular bearings of each lens are measured separately.

The longitudinal component is measured with the microscope vertical so that the eye is seen directly from above (text-fig. 3a). The left eyepiece assembly with its pointer (C) is rotated in its fixed barrel until the set of lines on the graticule parallel with the pointer has the same angular bearing as the axis of the lens. The other set of lines on the graticule are now parallel with the principal plane of the lens. The pointer now records the longitudinal component on the protractor (F). Each lens is examined in turn by this method.

The microscope body is restored to the horizontal position (text-fig. 2), in order that the latitudinal components may be measured. For each lens, the turntable is rotated so that the pointer (L) shows the already recorded longitudinal bearing of the particular lens under investigation and its profile may be observed through the microscope as it projects from the curving surface of the eye (text-fig. 3b). The graticule is then used for the determination of the latitudinal bearing of this and other lenses in the manner already shown.

All the dorso-ventral files are brought into view in turn for study but with continued rotation of the turntable, either the glabella or the high posterior border may move into the field of view and obscure the lenses of the first or the last few files. The turntable is then reversed through  $180^\circ$ , and the lenses are measured from the opposite direction.

In both sets of measurements, the close spacing of the lines in the graticule ensures considerable accuracy. Repeated measurements on the same eye have shown that the margin of error is generally less than  $1^\circ$  and never more than  $2^\circ$ . The ease of measurement with which this degree of accuracy can be attained depends, however, on the detailed morphology of the lenses and the sclera.

In *Acaste* the individual lenses project above the surface of the interlensar sclera, and the junction between lens and sclera is normally very distinct (text-fig. 1). In some other Phacopina, and particularly in *Phacops* s.s. (text-fig. 3a, b) the sclera may be highly inflated so that each lens appears sunken in a shallow crater-like depression. When one of these lenses is seen directly in profile, the lens/sclera junction may be just obscured by the inflated sclera. The uppermost lenses may, furthermore, be set obliquely to the surface of the sclera, and the lower rims of the depressions in which they lie may be more strongly pronounced than the upper rims. All the axes of such lenses in consequence have a lower

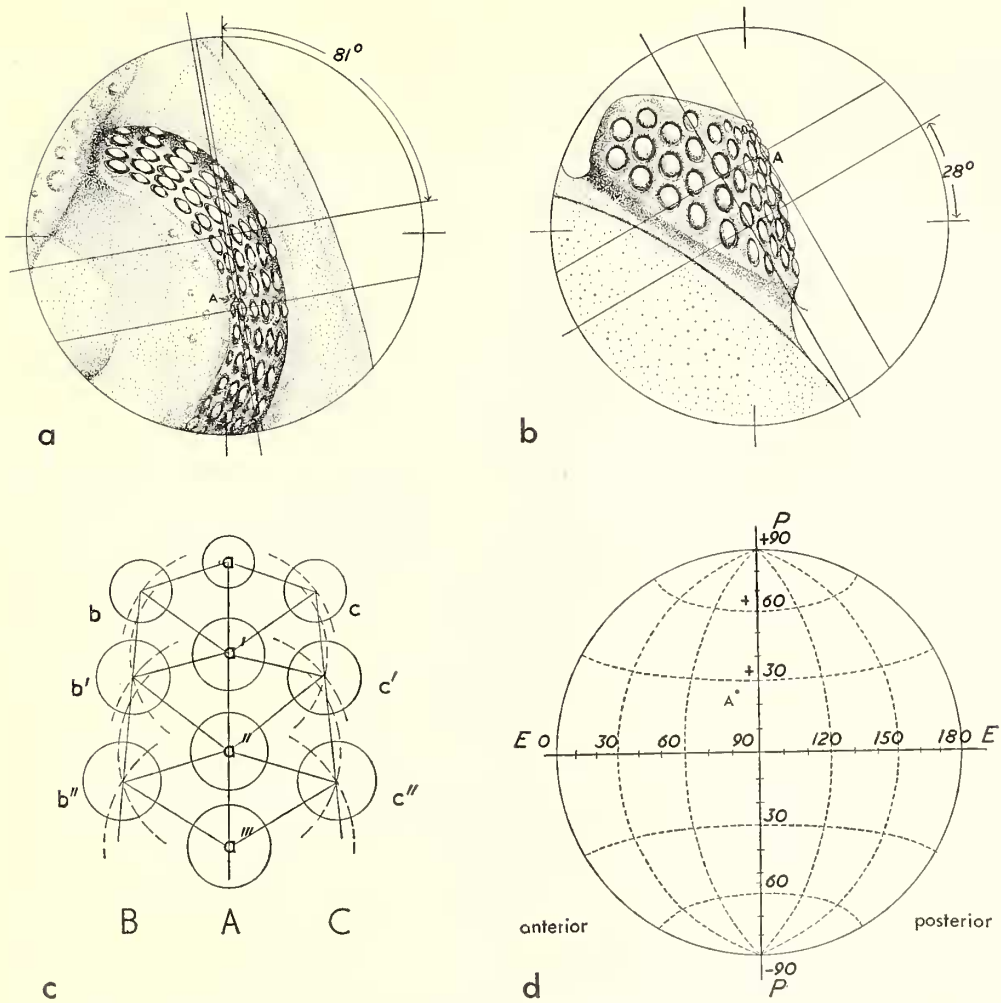

TEXT-FIG. 3. Technique of measurement of the spatial and angular relationships of the lenses. *a, b*, Angular directions of lens-axes of *Phacops latifrons* Bronn. The two sets of perpendicular lines represent the central cross wires of the graticule, and parallel lines following the optic axis and principal plane of the lens. Other graticular lines have been omitted for clarity. Lens A has latitudinal and longitudinal axial bearings of  $28^\circ$  and  $81^\circ$  respectively; *c*, Triangulation of lens-centres in files B and C from those of file A; *d*, Lambert equal-area net with notation adopted for recording bearings of lens-axes. The bearing of the axis of lens A (*vide* text-fig. 3*a* and *b*) is indicated.

latitudinal elevation than if they had been set flush with the surface, with their principal planes parallel with the outside of the sclera. In making accurate estimations of the latitudinal bearing of such lens-axes, the lens must be kept in focus as it is being rotated into position for measurement.

When the longitudinal and latitudinal components have been measured, the resultant bearings of all the lens axes are plotted upon a Lambert equal-area stereographic net (text-figs. 5, 6). Text-fig. 3*d*, shows the notation adopted in the description of the axial bearings of the lenses.

The term 'visual field' is used here to include the area enclosed by the peripheral lens-axes. As each individual ommatidium presumably had a certain visual field of its own, however, the actual field of

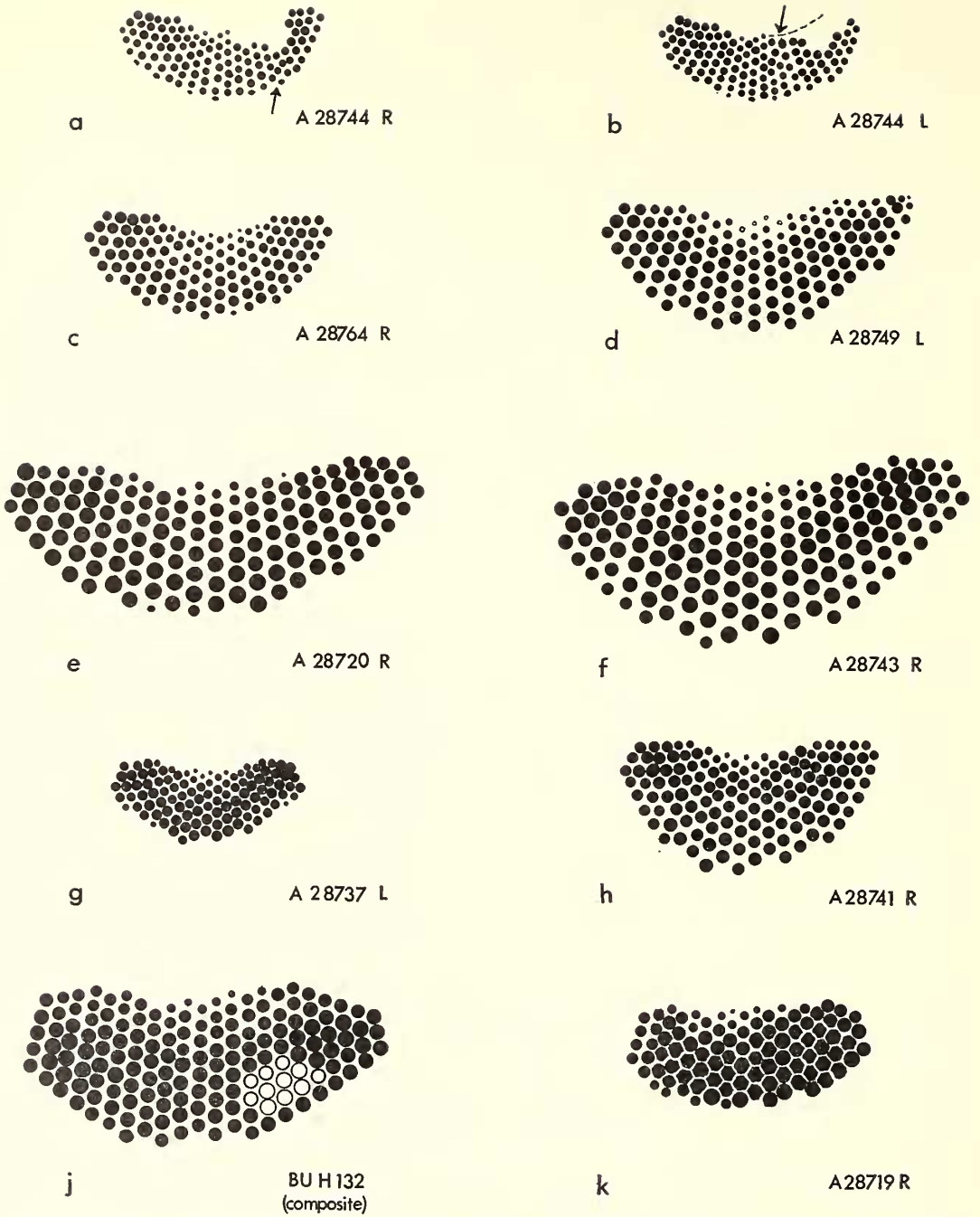

TEXT-FIG. 4. Projected visual surfaces of Acastinae. All  $\times 10$ . *a-f*, *Acaste downingiae* (Salter) s. str., eye-variant A; *g-h*, *A. downingiae* s. str., eye-variant B; *j*, *Acaste downingiae macrops* (Salter), composite figure from both eyes. The blank circles represent badly weathered lenses; *k*, *Acastoides constricta* (Salter). The anterior edge is at the left-hand side in all these diagrams. Thus right eyes (R) are viewed from within; left eyes (L) from outside. In SM A 28744 the visual surfaces are slightly damaged. Irregularities in lens-distribution are marked by arrows.



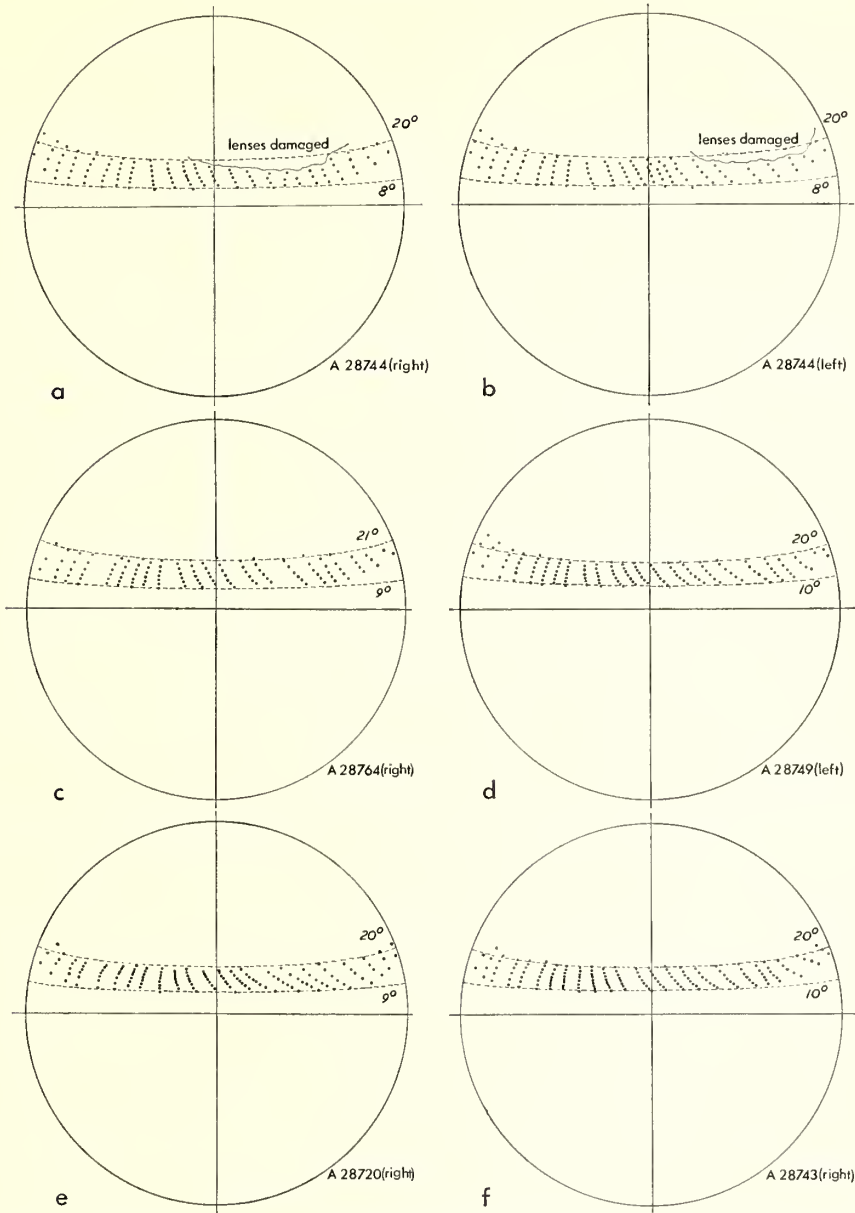

TEXT-FIG. 5. Visual fields and axial bearings of lenses shown by stereographic projection. a-f, *Acaste downingiae* (Salter) s. str., eye-variant A.

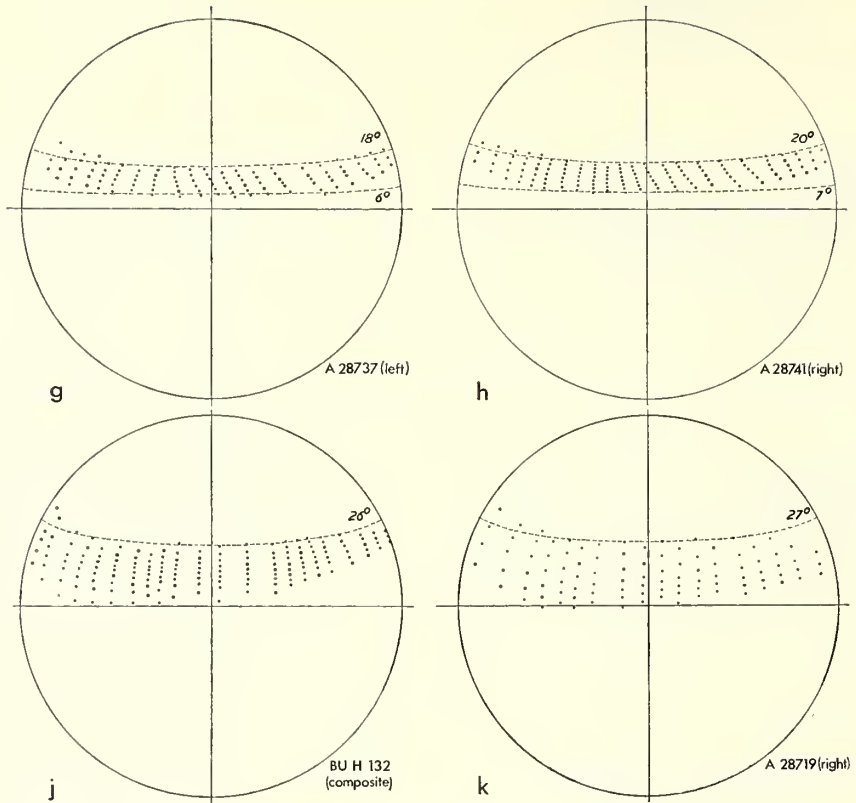

TEXT-FIG. 6. Visual fields and axial bearings of lenses (cf. text-fig. 5) *g, h*, *Acaste downingiae* (Salter) s. str., eye-variant B. *j*, *Acaste downingiae macrops* (Salter), composite figure from both eyes; *k*, *Acastoides constricta* (Salter).

view of the trilobite eye as a whole probably extended some way outside the visual field shown on the stereogram (p. 25). The term is retained for convenience of description.

#### FUNCTIONAL DESCRIPTIONS OF THE EYES OF ACASTINAE

##### *Acaste downingiae* (Murchison 1839)

This species occurs in the Wenlock Limestone (Silurian) of Dudley and the Welsh Borderland. Murchison's original description (1839, p. 655, pl. 14) is very brief, and the fullest existing accounts of the species are those of Salter (1853, 1864) in which six varieties are enumerated. In the definition of these varieties, Salter used various morphological criteria, including the external structure of the eye, which, as he observed, varies considerably within the species. Although the following detailed studies of the eyes of *A. downingiae* have given further information which might be of some taxonomic value, it is not the purpose of this paper to attempt any further systematic interpretation of the species, and Salter's varieties, as revised by the Richters (1954), are retained,

pending taxonomic revision of *A. downingiae* and related species by Shergold which is now in press (personal communication).

The exoskeleton of this species appears to have been remarkably resistant to pressure, as compared with some other Wenlockian Phacopina and Cheirurina which are frequently found to be crushed. Hence 40 out of the 62 specimens of '*A. downingiae*' in the Sedgwick Museum, with cephala ranging in length from 3.5 mm. to 11 mm., are almost perfectly preserved and show no trace of distortion. Most of the very best specimens are enrolled and a few are partially silicified. Extremely small, though crushed, specimens are known and in some of these the lenses can be distinguished.

Almost all the Sedgwick Museum specimens have been identified as *A. downingiae* s. str. (Salter). Of Salter's other varieties, no material showing intact eyes of *A. downingiae inflatus* (Salter), *A. downingiae cuueatus* (Salter) or of *Acastella spinosa* (Salter) has been available for examination. A single almost perfect specimen of *A. downingiae macrops* (Salter) with well-preserved eyes was lent by the Geology Department of Birmingham University and two specimens of *Acastoides constricta* (Salter) were in the Sedgwick Museum collection. These latter species are described in a later section of this paper.

*Acaste downingiae* (Salter 1864) s. str.

Plates 1, 2; Plate 3, figs. 1-3.

1839 *Calymene* ? *downingiae* Murchison, p. 655, pl. 14, fig. 3a.

1851 *Phacops downingiae* (Murch. sp.); M' Coy, p. 160.

1853 *Phacops downingiae* Murchison; Salter, p. 1-12, pl. 1, figs. 1, 2, 5-13, 15.

1864 *Phacops (Acaste) downingiae* Murchison, var.  $\alpha$  *vulgaris* Salter, p. 26, pl. 2, figs. 17-25.

1954 *Acaste (Acaste) downingiae* (Murchison 1839); R. and E. Richter, pp. 16-17, pl. 3, figs. 36-41.

A comparison of Salter's descriptions and figures with the Sedgwick Museum specimens indicates that within Salter's 'variety' there are at least two distinct forms differing in the size and position of the eye, the character of the visual surface, the degree of inflation of the glabella, and the character of the genal angles.

The eyes of the two forms which he figured are quite distinct and do not have any morphological intermediates. About three-quarters of the fully grown Sedgwick Museum specimens have large eyes with more widely spaced lenses and rounded genal angles as in Plate 1, fig. 8 (cf. Salter 1853, fig. 1). This form will be termed eye-variant A. The rest of the specimens have smaller eyes with more closely spaced lenses and pointed genal angles (ibid. fig. 2) and are referred to as eye-variant B. The two types of eye also differ in the number and arrangement of the lenses within the visual surface.

The existence of two eye-variants, which are often associated with minor morphological differences in the cephalon, has also been detected in *Phacops rana* (Green), *P. latifrons* (Bronn), *P. breviceps* Barrande, and *P. fecundus* Barrande by the present author.

In *Acaste downingiae* s. str. five fully preserved specimens of eye-variant A (SM A 28744, -64, -49, -20, and -43) and two of eye-variant B (SM A 28737, -41) have been selected for analysis as representative examples of individuals of different sizes. Comparisons were made throughout with other specimens of equivalent dimensions. In each eye-variant specimens of the same size normally have a very similar number of lenses.

*Eye-Variant A.* Text-figs. 1*a*, *b*; 4*a-f*; 5*a-f*; 7*a-e*; 9*a-e*; Plate 1, figs. 1-9; 2, figs. 1-4; 3, figs. 1-3.

Eyes of moderate size, not particularly prominent, occupying the central third of the cephalic length (sag), and extending from glabellar furrow 3*p* almost to the posterior marginal furrow. The anterior edge almost reaches the axial furrow, but the posterior edge is free and lies further from the sagittal line. In profile (Pl. 3, fig. 1) the eye-base lies about half way between the genal angle and the crown of the glabella, but the palpebral lobe does not quite reach the level of the latter. Curvature of visual surface in dorsal aspect quite strong, profile curvature extremely low (text-fig. 1, Pl. 1, fig. 8). The visual surface rises abruptly from an indistinct eye-platform, is bounded ventrally by a shallow groove, and projects slightly laterally. Both the upper and lower eye borders are parallel in young specimens but in older ones the lower border is downwardly convex. Palpebral lobe granulated, consisting of a narrow flattened outer strip running parallel with the facial suture, and sloping first gently, then steeply to the palpebral furrow. In some specimens a narrow line of shallow pits can be seen near the outer rim of the palpebral lobe running parallel with the facial suture (Pl. 2, fig. 3). Palpebral area very granular, shelving gently towards the axial furrow, open posteriorly.

Lenses (see Table 1) normally disposed regularly in 22-24 files, but in the smallest specimen (SM A 28744. Text-fig. 4*a-b*, 5*a-b*, 7*a-b*) there are two extra lenses in the right eye and a hiatus in the centre of the left eye, which breaks up the regularity of the visual surface. Such irregularities are uncommon. In the smallest specimen the angle at which the files diverge ventrally is high, but in the largest specimens some of the central files are subparallel. The lenses of small specimens are almost uniform in size (Table II and text-fig. 9) and spaced at about the distance of a lensar radius from each other (cf. Salter 1853, pl. 1, fig. 8). Subsequently, size differentiation appears, and in the larger specimens the upper central region of the visual surface contains small lenses lying between the horns of a crescent of larger lenses which increase in diameter downwards. At the lower ends of the diagonal rows, the lenses are often small and immature. In SM A 28744 (text-fig. 4*a-b*) the lowest lenses are elliptical and set close in under the lenses above them, but in larger specimens the corresponding lenses are never elliptical. An accessory upper horizontal row is usually present, extending posteriorly from about the centre of the eye.

The interlensar sclera may be flat or slightly inflated, and is covered with minute granules. Ventrally they become continuous with the granules of the lower rim of the visual surface.

---

#### EXPLANATION OF PLATE I

*Acaste downingiae* Salter, s. str. Eye-variant A. Wenlock Limestone, Silurian. Dudley, England.

Figs. 1, 2, 4, 5, 7. Small specimen, SM A 28744. Right eye, lateral aspect,  $\times 20$ . 2. From above,  $\times 5$ . 4, 5, 7. Right eye, lateral aspect,  $\times 20$ .

Figs. 3, 6. SM A 28749. Left eye, lateral and dorsal aspects,  $\times 7.5$ . In fig. 6 the eye of a neighbouring specimen of the same species is visible on the left-hand side.

Fig. 8. SM A 28764. Right eye, lateral aspect,  $\times 15$ .

Fig. 9. SM A 28720. Lenses near lower rim of right eye,  $\times 25$ .



1



2



3

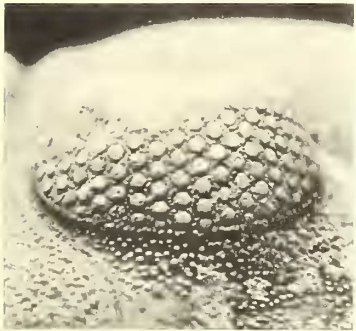

4



6



5

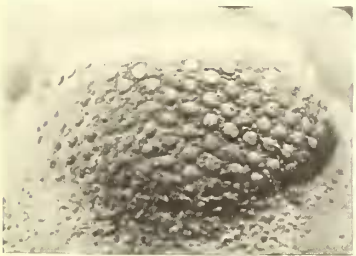

7

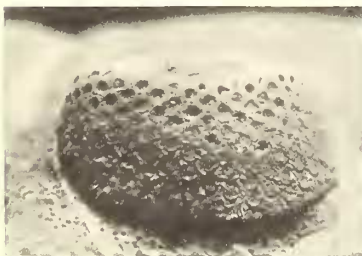

8

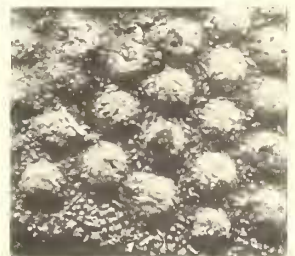

9



*Eye-variant B.* Text-figs. 4*g, h*; 6*g, h*; 8*a-b*; 9*f, g*; Plate 2, figs. 5-8.

Eyes smaller than in eye-variant A, situated more towards the rear of the cephalon and not reaching anteriorly quite as far as glabellar furrow 3*p*. Palpebral lobe more highly inflated than that of eye-variant A, curving uniformly downwards to the axial furrow, with less trace of a palpebral furrow. Similar shallow pits to those seen in eye-

TABLE 1—Distribution of lenses

*Acaste downingiae* (Salter) s. str.

*Eye-variant A*

Specimen	Number of lenses per file (front to rear)								Total	Max. per file
	345	666	667	677	555	4 (2) 33	334	32		
SM A 28744 (Rt)*	345	666	667	677	555	4 (2) 33	334	32	111	7
SM A 28744 (Rt)†	345	666	667	677	676	6 (2) 66	554	32	127?	7
SM A 28744 (Lt)*	345	666	667	677	7 (5) 66	654	333	22	121	7
SM A 28744 (Lt)†	345	666	667	677	7 (5) 66	666	554	32	130?	7
SM A 28764	345	666	767	676	776	766	543	2	122	7
SM A 28749	345	677	778	788	888	766	654	3	138	8
SM A 28720	345	677	777	787	777	767	665	43	140	8
SM A 28743	1456	788	889	889	888	877	665	43	159	9

N.B. In SM A 28744 the upper posterior parts of both eyes are slightly damaged.

\* Number of lenses actually preserved. † Probable original number. ( ) Small extra lenses interpolated between complete files and breaking up the regularity of the visual surface (p. 12).

*Eye-variant B*

SM A 28737	345	556	567	666	656	655	543	—	109	7
SM A 28741	345	677	778	787	777	676	654	32	136	8

*Acaste downingiae macrops* (Salter)

BU H 132	567	889	989	989	999	887	654	3	163	9
----------	-----	-----	-----	-----	-----	-----	-----	---	-----	---

*Acastoides constricta* (Salter)

SM A 28719	456	666	676	666	565	543	—	—	98	7
------------	-----	-----	-----	-----	-----	-----	---	---	----	---

variant A lie in a curve just inside the facial suture. Visual surface very compact, just over twice as wide as it is high. All the dorso-ventral files diverge ventrally at quite a high angle. Lenses (Tables 1, 2) arranged in a similar pattern to those of eye-variant A but very much more closely packed. The largest lenses are often contiguous, even in small specimens.

*Character of visual field.* As can be seen on the stereogram (text-fig. 6*g, h*), the longitudinal visual limits are normally 0-180°, in both eye variants. The latitudinal limits are somewhat variable, but are generally in the region of 10-20° in eye-variant A and 8-20° in eye-variant B. The upper visual limit is fully latitudinal (text-fig. 6*g, h*) except at the extreme anterior and posterior edges where it rises slightly higher. The lower limit

is latitudinal anteriorly, but towards the rear the elevation of the lowest lens-axes rises, so that a shallow postero-ventral 'lacuna' is formed. In some cases a smaller anterior lacuna may be present.

TABLE 2—Dimensions of cephalon, eyes and lenses (in mm.)

*Acaste downingiae* (Salter) s. str.*Eye-variant A*

Specimen	Cephalon		Eye					Lens diameters		
	*L(sag.)	W	L(max.)	L(min.)	W(max.)	W(min.)	H	Large	Average	Small
SM A 28744	3.5	7.5	1.9	1.55	1.2	0.9	1	0.1	0.1	—
SM A 28764	5.5	12	2.5	2.1	1.5	1.25	1.3	0.14	0.125	—
SM A 28749	7.5	14	2.9	2.5	2.2	1.5	2	0.175	0.165	—
SM A 28720	10.5	18	3.5	3.1	2.25	1.5	2	0.25	0.23	0.1
SM A 28743	11.5	21	4	3.6	2.4	1.75	2.25	0.275	0.25	0.175

*Eye-variant B*

SM A 28737	5	9	1.75	1.5	1.25	1	1	0.14	0.125	—
SM A 28741	8	15	3	2.75	2	1.75	1.75	0.175	0.165	0.05

*Acaste downingiae macrops* (Salter)

BU H 132	6.5	11	3.5	2.5	2.5	2.0	2.25	0.25	0.2	—
----------	-----	----	-----	-----	-----	-----	------	------	-----	---

*Acastoides constricta* (Salter)

SM A 28719	7	10	3	2.3	2	1.5	1.7	0.2	0.175	0.075
------------	---	----	---	-----	---	-----	-----	-----	-------	-------

\* L, W, H = length, width, and height as in text-fig. 1.

The strong differentiation between plan and profile curvature of the visual surface results in the concentration of the lens-axes into distinct and widely spaced 'visual strips', which of course correspond to the dorso-ventral files and diverge radially from the top to the bottom of the visual field. In the anterior and posterior visual strips of the larger specimens (text-fig. 5e, f) the lowest lens axes form a higher angle with the polar meridian than the upper ones. In the region of file 8 each strip tends to lie in a single longitude, but anteriorly and posteriorly they become more oblique and are often curved. The average spacing of adjacent strips is in the region of 7° at the top and 10° at the bottom, but posteriorly it may increase to 10° and 15° respectively.

## EXPLANATION OF PLATE 2

Figs. 1-4. *Acaste downingiae* (Salter) s. str., eye-variant A. Wenlock Limestone. Silurian. Dudley, England. 1-3, SM A 28720, right eye. 1, Lateral aspect,  $\times 7.5$ . 2, Lenses near the anterior margin,  $\times 25$ . 3, Dorsal aspect,  $\times 7.5$ . 4, SM A 28743. Right eye, lateral aspect,  $\times 7.5$ .  
Figs. 5-8. *Acaste downingiae* (Salter) s. str., eye-variant B. Same locality and horizon. 5, 6, SM A 28737. Left eye, lateral and dorsal aspects,  $\times 20$ . 7, 8, SM A 28741. Left eye, lateral and dorsal aspects,  $\times 7.5$ .





1

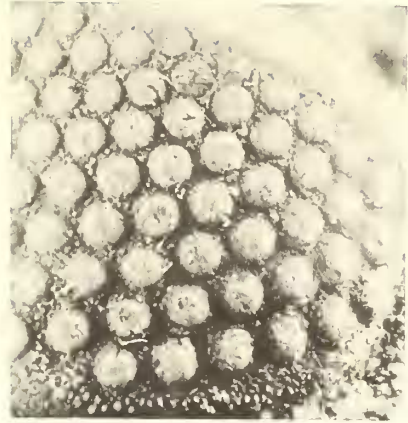

2



3



4



5

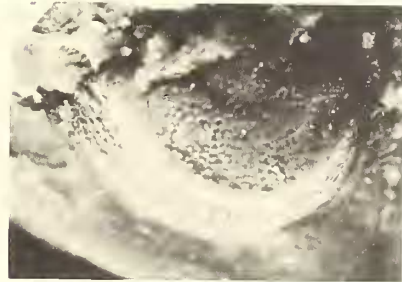

6



7

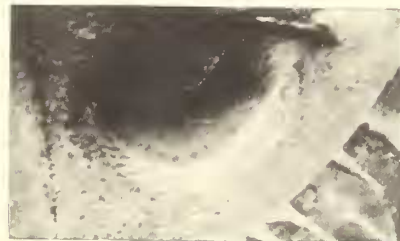

8



Angles separating adjacent lens-axes within the strips are very low. Even in the youngest stages, they are only  $1^\circ$  or  $2^\circ$  in the long central files, and  $3^\circ$  or  $4^\circ$  in the outer files.

The visual field of both eye-variants is very similar, but in eye-variant B the visual strips are more regular and less highly slanted.

*Post-larval development of the visual surface.* Ontogenetic studies of the eyes are complicated by the existence of the two eye-variants. This has led to divergent interpretations of ontogeny. For example, Clarke (1889) charted the number and arrangement of the lenses in various specimens of *Phacops rana* (Green), and showed that there was a definite relationship between the number of lenses in the eye and the size of the specimen. Equating size with age he concluded that the number of lenses increased from youth to maturity, and then decreased from maturity to senility. He believed that the extra lenses present in the smaller specimens had been later absorbed by sclerosis, due to the growth of the interlensar sclera or the migration of the lenses below the surface of the palpebral lobe. The strong inflation of the sclera in the older specimens was used as evidence in support of this hypothesis.

Beckmann (1951), who worked with *Phacops* cf. *breviceps* and *Phacops schlotheimi*, found no such apparent diminution in lens number with senility, but only an increase until full maturity was reached. Further, using Clarke's measurements of specimens of *P. rana*, Beckmann produced a graph showing the number of lenses compared with the width of the cephalon. This graph indicated that Clarke's material was composed of two distinct elements, in one of which the cephalons were small and the lens number large, and in the other the cephalons were large and the lens number small. He suggested that since Clarke's material came from various localities in North America, two ecologically distinct faunas were present which had probably been mixed prior to examination. In the species which Beckmann investigated there was apparently only one fauna, and hence only one type of eye.

The probability that Clarke had inadvertently included more than one type of eye in his analyses is enhanced by Stumm's (1953) systematic revision of *P. rana*. Stumm distinguished a number of subspecies using the character of the eye as a diagnostic feature. The significance of Stumm's work is to be discussed in a later paper.

Neither Beckmann nor Clarke referred to the work of Barrande (1852, p. 514, pl. 21) who recorded the lens number and distribution in 12 specimens of *Phacops fecundus* Barrande, noting that the largest specimens never had as many lenses as the smaller ones. Barrande attributed this to the considerable degree of intraspecific variation characteristic of this species. His figures (pl. 21, fig. 19) show that the longest file of the largest specimen only has 5 lenses, whereas the maximum number recorded, in a smaller specimen, was 9. In the largest specimens the interlensar sclera is inflated and the lenses are rather widely spaced. Hence there is a strong resemblance between the condition of *P. rana* and that of *P. fecundus*.

The present studies tend to confirm Beckmann's view that two distinct elements were present in Clarke's material. But in *Acaste downingiae* s. str. the two variants commonly occur in faunas which were collected at a single locality and are, therefore, unlikely to be the result of ecological control. No evidence of lensar sclerosis or absorption by the palpebral lobe has been collected, and Clarke's hypothesis of decrease of lens number with senility has been abandoned.

In the earlier growth stages the distinction between the two eye variants is less marked. Immature specimens of eye-variant A may have small genal spines resembling those of eye-variant B, which become progressively reduced and finally disappear. Thus in the series referred to, A 28744 has a short genal spine, A 28764 has pointed genal angles, A 28749 has a barely perceptible point, and in A 28720 and A 28743 the genal angles are fully rounded, with no trace of a point.

During ontogeny the eyes in eye-variant A double in length and more than double in height in their development from the youngest preserved stage. The relative increase in height is due to an increase in number of lenses in the files. The angle at which adjacent files diverge decreases through development. The size and spacing of the lenses increase progressively from youth to maturity but remain approximately constant relative to the size of the whole visual surface.

The conclusions of Clarke and Beckmann, that the lenses increased in number with age, and in a particular order, have been confirmed in general, though it seems that the eye of *A. downingiae* is rather more variable than the species which they investigated.

From Table 1 and the diagrams of the visual surface (text-fig. 4) we may draw the following conclusions:

1. The full lens complement of the upper and accessory upper horizontal rows was already developed from an early stage (SM A 28744) and no more lenses were added to the upper ends of the dorso-ventral files; these rows remained complete and separate entities. Beckmann showed that in *P. cf. breviceps* and in *P. schlotheimi* some lenses were added at the upper ends of the files, but his youngest specimens seem to represent an earlier stage in development than any yet seen in *A. downingiae*, where the youngest specimen has already a maximum of seven lenses per file. It is possible that in earlier stages in the development of the eye of *A. downingiae* lenses may have been added immediately below the facial suture.

2. As Clarke has suggested, new lenses were added exclusively at the lower ends of the files, i.e. at the lowest points of the visual surface, at least during the growth stages studied. But as the species is more variable than those which Clarke and Beckmann studied, it has not been possible to produce diagrams like those of Beckmann (Abb. 278/3), showing the order of development of the lenses. The newly developed lenses are small and set closely below the preceding lenses. Generally they are circular but in the young stages of eye-variant A they are elliptical. The immature lenses may be compared with the corresponding lenses on larger specimens, and by comparison with the latter it appears that only when they have grown to their full size do new lenses arise below them. The manner of emplacement of new lenses appears to resemble that described by Clarke for *P. rana*. He showed by sections that the 'ommatidial cavities' arise by evagination of the sclera from below, and these cavities meet with the outer surface where

#### EXPLANATION OF PLATE 3

- Figs. 1-3. *Acaste downingiae* (Salter) s. str., eye-variant A. Wenlock Limestone. Silurian. Dudley, England. 1-3, SM A 28720. Lateral, dorsal, and anterior aspects of enrolled specimen,  $\times 2$ .  
 Figs. 4-9. *Acaste downingiae macrops* (Salter). Same locality. BU H132, 4, 5, 6, 9. Lateral, anterior, and dorsal aspects of enrolled specimen,  $\times 4$ . 7, 8. Right and left eyes, lateral aspect,  $\times 7.5$ .  
 Figs. 10-12. *Acastoides constricta* (Salter). Same locality. 10, SM A 28719. Right eye, lateral aspect. 11, 12, SM A 28719. Lateral and dorsal aspects of enrolled specimen,  $\times 3\frac{1}{2}$ .



1



2

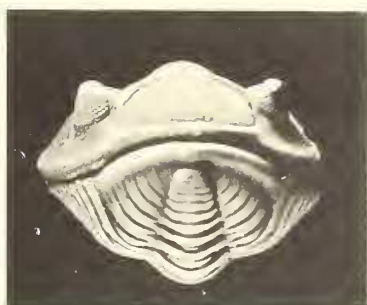

3



4



5



6



7



8



9



10



11



12



there may be a corresponding inward invagination. Some of his sections showed immature cavities which had not penetrated the outer surface. The size of all the lenses increases progressively during ontogeny, remaining approximately constant relative to the size of the whole visual surface. There are marked variations, however, in the size of the lenses in different parts of the visual surface. The lenses along the upper border,

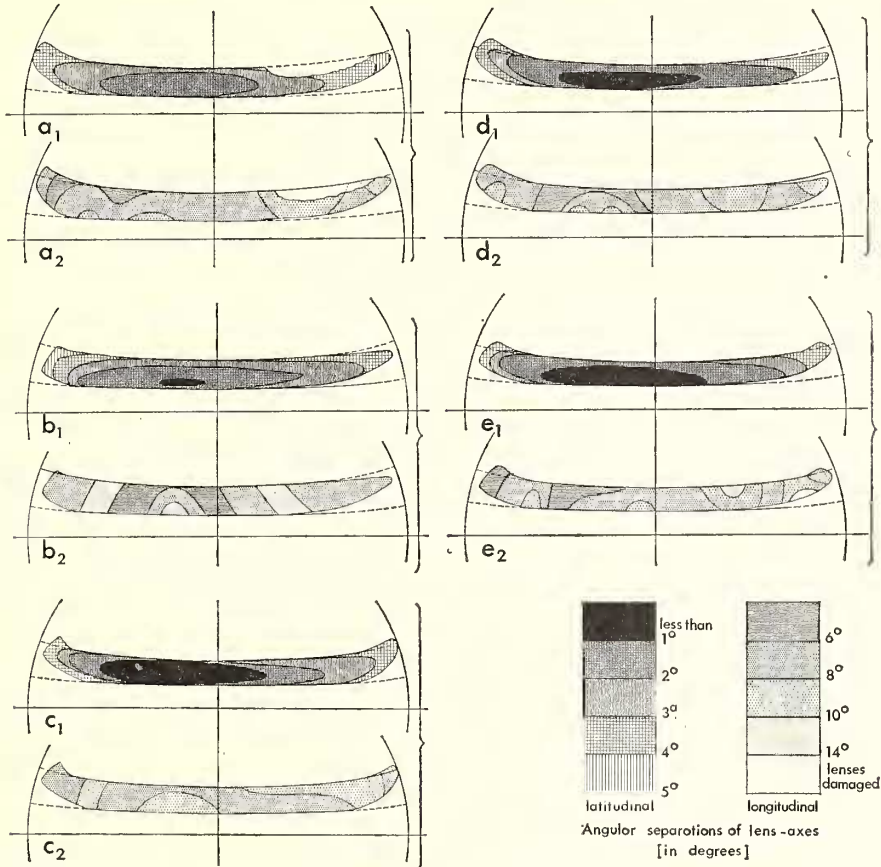

TEXT-FIG. 7. Latitudinal ( $a_1, b_1$ , etc.) and longitudinal ( $a_2, b_2$ , etc.) angular separations of the lens-axes, axial angles represented by contoured stereograms (cf. text-fig. 5). *a-e*. *Acaste downingiae* (Salter) s. str., eye-variant A. *a*, SM A 28744, left eye; *b*, SM A 28764, right eye; *c*, SM A 28749, left eye, *d*, SM A 28720, right eye; *e*, SM A 28743, left eye.

and to a lesser degree, the lower border remain relatively small, whereas those in the antero-lateral and postero-lateral sectors become relatively large. The differentiation is more pronounced in the later growth stages.

Changes within the visual field are represented by a series of stereograms (text-figs. 7, 8) which show the angular separations of the lens-axes by contouring. Latitudinal and longitudinal separations are indicated on separate diagrams. For latitudinal separations  $1^\circ$  contours were found to be suitable, but owing to the irregular spacing of the visual strips,  $2^\circ$  and  $4^\circ$  contours have been used to show longitudinal separations.

It is apparent from these and from the original stereograms (text-figs. 5, 6), that throughout the development of the eye, there are no major changes in the angular extent of the visual field. Apart from some slight intraspecific variation, the angular range of vision of an eye with 127 lenses differs little from one with 159. The longitudinal extent of vision of specimens with 22, 23, or 24 files is virtually the same ( $180^\circ$ ) and whether there is a maximum of 7, 8, or 9 lenses per file, the latitudinal extent is always of the order of  $11^\circ$  in eye-variant A, or  $13^\circ$  in eye-variant B. The extra lenses added with growth are orientated so that their axes remain within the prescribed visual

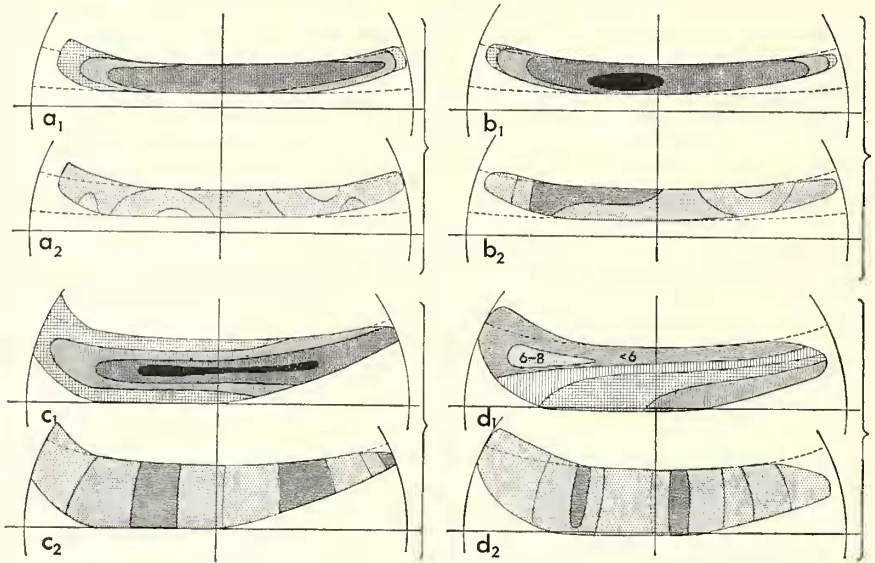

TEXT-FIG. 8. Latitudinal ( $a_1, b_1$ , etc.) and longitudinal ( $a_2, b_2$ ) angular separations of the lens-axes. Cf. text-fig. 6. *a, b*, *Acaste downingiae* (Salter) s. str., eye-variant B. *a*, SM A 28737, left eye; *b*, SM A 28741 right eye; *c*, *Acaste downingiae macrops* (Salter), BU H 132, composite figure from both eyes; *d*, *Acastoides constricta* (Salter), SM A 28719, right eye.

field. As the number of lenses increases, their latitudinal separation decreases, particularly (text-figs. 7*a*<sub>1</sub>, *b*<sub>1</sub>, *c*<sub>1</sub>, etc., 8*a*<sub>1</sub>, *b*<sub>1</sub>, *c*<sub>1</sub>), in an elliptical region in the lower central part of the visual field surveyed by the longest files ( $40\text{--}120^\circ$  long.;  $10\text{--}17^\circ$  lat.). At all stages during ontogeny zones of increasing latitudinal separation are concentric with this region and the highest separations are found at the anterior and posterior visual limits. The profile curvature of the visual surface remains virtually constant throughout growth. The latitudinal elevation of the lowermost lens-axes must rise as new lenses are added below them, hence the axial bearing of any one of these new lenses will be similar to the original direction of the lens-axis now above it.

Changes in the longitudinal separation of the visual strips are less apparent, chiefly because so few lenses are added at the anterior and posterior edges of the eye. The total number of visual strips increases only from 22 to 24, and the pattern in which these strips are arranged remains constant throughout (text-figs. 5, 6). The appearance of the visual strips reflects the topographical situation of the lenses on the visual surface.



When the eye of *A. downingiae* s. str. is examined from directly above (text-fig. 1*b*), each lens of the anterior files appears slightly offset on the curving visual surface with regard to the lenses below and above it so that the axes of the lower lenses are directed more anteriorly than those of the upper lenses of the same file. This angular difference decreases posteriorly so that in the longest files all the lenses in one file have about the same longitudinal axial bearing. In the succeeding files the reverse situation to that of the anterior files is apparent.

Thus on the stereograms (text-figs. 5, 6) the separation of the visual strips corresponding to these files increases vertically except for the central longitudinal strips, which correspond to files 8 and 9. In young specimens the visual strips are almost straight. In older specimens the new lenses which have been added to the lower ends of the diagonal rows each have a slightly different longitudinal axial bearing from the lenses about them (except in the longitudinal strips), so that the total longitudinal range of the diagonal visual strips increases with age. On the stereogram the strips now become more highly slanted and may be curved. The tendency for the axis of the top lens of any one strip to have the same longitudinal bearing as that of the bottom lens of the adjacent strips, in the anterior and posterior parts of the visual field, appears in the youngest stages and becomes more pronounced during the later development of the eye. This is apparently a device which enables the whole of the visual field to be covered by the visual strips with maximum economy of lenses. The apparent complexity of the contoured stereograms showing longitudinal separations of the lens-axes (text-figs. 7  $a_2$ ,  $b_2$ ,  $c_2$ , etc.; 8  $a_2$ ,  $b_2$ ) is the result of the variability in spacing of the visual strips, which may range from 5° to 12° or more.

Comparison of the two sets of contoured stereograms (text-figs. 7  $a_1$ ,  $a_2$ ,  $b_1$ ,  $b_2$ , etc., 8  $a_1$ ,  $a_2$ ,  $b_1$ ,  $b_2$ ) indicates that regions of maximum or minimum longitudinal separation do not necessarily coincide with like regions of latitudinal separation.

At this point it is interesting to consider the coverage of the visual field by lenses of varying sizes. This is again best represented by contoured stereograms (text-fig. 9). These stereograms indicate how, whilst the lenses increase in size during ontogeny, those regions of the visual field covered by the largest and by the smallest lenses remain relatively constant. The actual pattern of coverage differs in the two eye-variants. Thus in eye-variant A, the largest lenses survey regions close to the anterior and posterior visual limits, of which the anterior has the wider extent; whereas in eye-variant B, the lenses are more uniform in size and the two regions are less well marked.

Finally, the above stereograms (text-fig. 9), may be compared with the paired stereograms showing axial separations (text-figs. 7, 8). There is some degree of relationship in this species between the size of the lenses and their latitudinal axial separations. The largest lenses cover the regions where axial separations are high, i.e. at the extremities of the visual field. The relationship between lens sizes and longitudinal axial separations is somewhat less obvious owing to the greater variability of the latter.

*Acaste downingiae macrops* (Salter 1864)

Plate 3, figs. 4-9.

1864 *Phacops (Acaste) downingiae* Murchison var.  $\beta$  *macrops* Salter, pp. 26-27, pl. 2, figs. 26-29.

Salter's (1853) description of *A. downingiae* included a brief account and figure of the

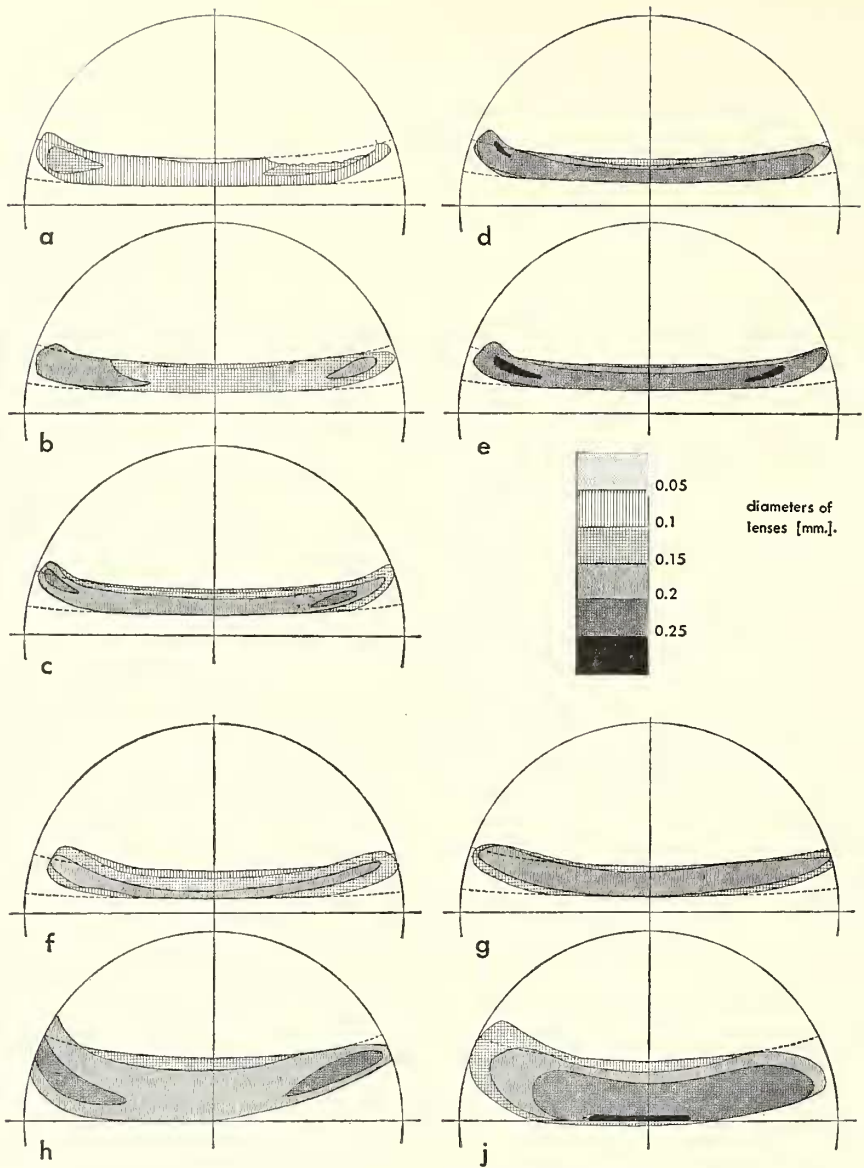

TEXT-FIG. 9. Contoured stereograms showing coverage of different regions of the visual fields by lenses of various sizes. *a-e*, *Acaste downingiae* (Salter) s. str., eye-variant A. *a*, SM A 28744, left eye; *b*, SM A 28764, right eye; *c*, SM A 28749, left eye; *d*, SM A 28720, right eye; *e*, SM A 28743, left eye; *f, g*, *Acaste downingiae* (Salter) s. str., eye-variant B. *f*, SM A 28737, left eye; *g*, SM A 28741, right eye; *h*, *Acaste downingiae macrops* (Salter), BU H 132, composite figure from both eyes; *j*, *Acastoides constricta* (Salter), SM A 28719, right eye.

'large-eyed' form of the species, in which he noted that the visual surface was almost double the size of the normal type and possessed about 180 lenses. In 1864 he gave this varietal status.

A single small enrolled specimen, BU H 132 from the Wenlock Limestone of Dudley has been analysed. Both eyes are preserved undistorted but in each the visual surface is slightly damaged and some lenses are missing. The surface of the left eye is the more complete but a few of the posterior lenses have been destroyed. The posterior region of the right eye is entire but anteriorly patches of lenses are absent. The diagram (text-fig. 4j) representing the projected visual surface is composite and is derived from measurements of the existing parts of both eyes.

*Morphology of eyes.* Eye very large, prominent, set towards the rear of the cephalon, and extending from glabellar furrow 3p to the posterior marginal furrow. Both the anterior and posterior edges of the eye lie almost in the same exsagittal plane. In profile the base of the eye is situated rather low on the cephalon, at less than half the distance from the genal angle to the crown of the glabella, and the palpebral lobe stands at about the same level as the latter. In plan the visual surface is parabolic and sharply flexed about the transverse line; profile curvature moderate, strongest nearest the upper and lower borders. The visual surface rises sharply from the indistinct eye platform, is bounded ventrally by a shallow groove, and projects laterally near to the antero-lateral border of the cephalon. Both eye borders are parallel. Palpebral lobe moderately broad (tr), flat and smooth, declining very sharply adaxially to the sunken palpebral furrow, which at its point of maximum flexure in the transverse line turns sharply through 90°. Palpebral area smooth, shelving gently toward axial furrow and open posteriorly.

Lenses (see Table 1) disposed regularly in 22 dorso-ventral files.

All files diverge ventrally at a very low angle. Lenses quite closely packed, showing comparatively little variation in size (see Table 2), though in the central files the largest lenses are slightly smaller than those of the penultimate anterior and posterior files. The first and last files have small lenses and the lowest lenses of the diagonal rows are of about the same diameter. Very small lenses are present in the centre of the upper horizontal row. An accessory upper horizontal row is present, which extends from files 13 to 17.

Interlensar sclera planar and finely granular. A hexagon of larger granules surrounds each lens.

*Character of visual field.* The stereogram (text-fig. 6j) shows the visual field, which has longitudinal visual limits of about 0–180°, with a small anterior overlap, and a maximum longitudinal range of 0–28°. The upper visual limit is fully latitudinal, whereas the lower is equatorial only between files 1 and 12, and rises posteriorly so that there is a fairly deep postero-ventral lacuna with a maximum latitudinal extent of 0–18°.

The lens-axes form distinct visual strips, which contrast with those of *A. downingiae* s. str. in several respects, most notably in that all except the few posterior strips are longitudinal. As a result of the parabolic plan curvature of the visual surface, these strips tend to be clustered in two regions, in front of and behind the polar meridian, where they are normally separated by angles of less than 10° longitude (text-figs. 6j, 8c<sub>2</sub>). Between the more widely spaced central strips the separation may be as high as 15°.

Differentiation in the profile curvature of the visual surface leads to strong variation

in latitudinal separation of the lens-axes within each strip (text-figs. 6j, 8c<sub>1</sub>). In a longitudinal band lying between 8° and 20° lat. axial angles are low (2–3°), but above and below this band the separation of lens-axes increased quite regularly to 6° or more.

The regions of minimal latitudinal and longitudinal separation almost coincide in *A. downingiae macrops*. The composite text-fig. 9h shows the coverage of the visual field by lenses of both eyes. Although the latitudinal extent of vision is greater than in *A. downingiae* s. str. a remarkably similar pattern is apparent. Likewise the sizes of the lenses bear no relationship to their axial separations.

*Acastoides constricta* (Salter 1864)

Plate 3, figs. 10–12.

1864 *Phacops (Acaste) downingiae* Murchison, variety or subspecies  $\epsilon$  *constrictus* Salter, pp. 27–28, pl. 2, figs. 13–16.

1954 *Acaste (Acastoides) constricta* (Salter 1864); R. and E. Richter, pp. 17–18, pl. 3, figs. 42, 43.

Salter (1864) noted that the eyes of this species were small and set very close to the glabella, having a total of 130 lenses each.

A single small enrolled specimen (SM A 28719) from the Wenlock Limestone (Silurian) of Dudley, was analysed. The right eye is complete and perfectly preserved. The left is damaged.

*Morphology of eyes.* Eyes small, not very prominent, lying close to glabella, situated in the posterior part of the cephalon, and extending from between glabellar furrows (1p) and (2p) to the posterior marginal furrow. Both the anterior and posterior edges lie in the same exsagittal plane, the anterior being separated from the glabella by a narrow space. In profile the base of the eye is set high upon the cephalon, almost two-thirds of the distance between the genal angle and the crown of the glabella, and the palpebral lobe is level with the latter. Plan curvature moderate, increasing behind the transverse line, profile curvature about half the former, decreasing posteriorly. The visual surface rises sharply from librigena, is bounded ventrally by a very shallow groove, and does not project laterally as far as the antero-lateral cephalic border. Both eye-borders are parallel. Palpebral lobe moderately broad (tr), inflated and somewhat tuberculate, bounded adaxially by a row of shallow pits, and shelving first gradually, and then steeply to the indistinct palpebral furrow. Palpebral area small, almost flat, and open posteriorly.

Lenses (text-fig. 4k and Table 1), disposed regularly in 18 dorso-ventral files. All files diverge ventrally at a rather low angle. Lenses packed so closely that over most of the visual surface they are hexagonal and only the smallest lenses are rounded. Within each file they increase ventrally in diameter, though in the first and last two files their diameter is constant. An accessory upper horizontal row of small round lenses extends from files 8 to 16. The lenses of the anterior two or three files are small.

Interlensar sclera hardly discernible between the hexagonal lenses, but where visible below the facial suture it is planar and smooth.

*Character of visual field.* The maximum extent of the visual field (text-fig. 6k) is 6–174° long.; 0–27° lat. The upper visual limit anteriorly lies slightly above the 27° latitude and the lower is truncated by a small anterior and a larger shallow posterior lacuna.

The lens-axes are widely separated and form longitudinal visual strips which are relatively indistinct because throughout the visual field longitudinal separations are rarely more than twice the latitudinal. The variation in longitudinal axial angles (text-figs. 6*k*, 8*d*<sub>2</sub>) resembles that observed in *A. downingiae macrops* so that there are two regions of minimal separation, anterior and posterior to the polar meridian. The latitudinal axial angles, however, vary in a manner quite unlike those hitherto observed (text-figs. 6*k*, 8*d*<sub>1</sub>). The region of minimal latitudinal separation lies directly above the postero-ventral lacuna, and the axial angles increase regularly to the upper and anterior regions.

The largest lenses (text-fig. 9*j*), unlike those of *A. downingiae* cover the lowermost central part of the visual field, but this region of coverage does not really correspond with the areas of maximal or minimal axial separation. Whereas the structure and visual characters of the eyes of *A. constricta* differ radically from those of *A. downingiae*, similar features have been observed in *Dalmanites caudatus* (Brünnich) and in other Phacopina.

#### COMPARATIVE VISUAL PHYSIOLOGY

A fuller interpretation of the physiology of vision in these trilobites will be deferred until descriptions of the visual attributes of other schizochroal eyes have been published, but the nature of vision in the trilobites studied here is briefly considered with reference to that of recent arthropods.

*Visual powers of single ommatidia.* The fundamental units of which all modern compound eyes are constructed are the radially arranged ommatidia. Each of these has the form of a tapering cylinder whose upper end is capped by a lens capable of transmitting light to the photoreceptive reticular cells below. In the eyes of trilobites only the lenses and the interlensar sclera are ever preserved and the structure of the eye below this level is unknown. It must be assumed that the underlying regions were similar in their organization to those of recent arthropods, and that below each lens lay an ommatidium-like unit.

Considering the remarkable variability in the separation of the lens-axes and presumably therefore of the ommatidia, it is of some importance from the physiological viewpoint to know the angular receptivity to light of single ommatidia, and whether or not the visual fields of adjacent photoreceptors could have overlapped. The possible conditions in trilobites cannot be ascertained directly, but may be inferred from the comparable eyes of recent arthropods, though even in these the functions of single ommatidia as individual units is hardly known.

Burt and Catton (1954) working with *Locusta*, and Waterman (1954) with *Limulus*, have shown that single ommatidia have a wide range of directional sensitivity. In *Locusta* each ommatidium has a visual field of about 20° solid angle, and in *Limulus* it has been shown that whereas high light sensitivity is centred within 10–20° of the optic axis, responses were still given to reasonable light intensities up to 80° or 90° away from it.

In such eyes the visual fields of adjacent photoreceptors must overlap considerably. It is possible that in trilobites the cones of light-receptivity of neighbouring ommatidia were wide enough to extend laterally into the spaces between their axes and even between